

Earth-Rite® PLUS™

Technical Specification and Certification Data

Mechanical Installation Data

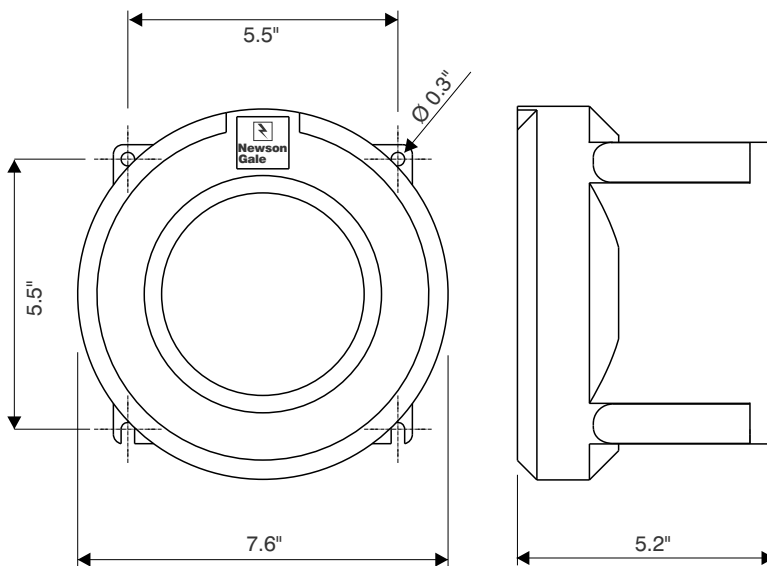

ATEX certified / UL Approved copper free cast aluminium enclosure - IP 66 / NEMA 4X, 7 & 9

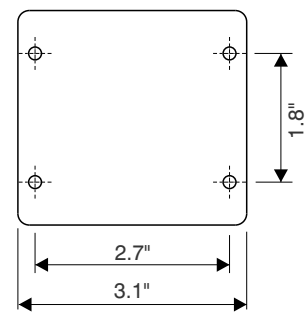
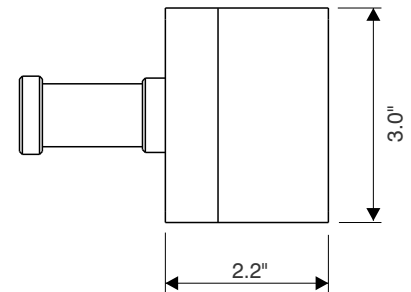

Simple Apparatus GRP clamp storage box with grounding clamp storage pin

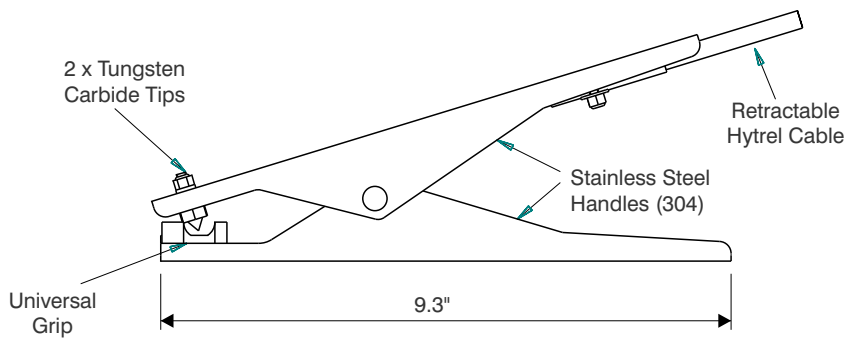

ATEX certified / FM Approved 2 Pole stainless steel grounding clamp fitted with one pair of tungsten carbide tips



SIL 2 IECEx



Electrical and Certification Data

Monitoring Unit

Power Supply	110/120V or 220/240V AC, 50-60 Hz 12V or 24V DC
Power Rating	10 watt
Ambient Temperature Range	-13°F to +122°F
Ingress Protection	NEMA 4X, 7, 9 (IP 66)
Weight	9.9 lbs (4.5 kg) nett
Construction	Copper-free cast aluminium
Hazardous Location Approvals	Class I, Div. 1, Groups A, B, C, D Class II, Div. 1, Groups E, F, G Class III, Div. 1 Ex d [ia] IIC / AEx d [ia] IIC DIP A21 T80C / AEx tD [iaD] 21 T80C
Monitoring Circuit	Intrinsically Safe
Operational Series Ground Resistance	Nominally <10 Ohm
Output Relay Contact Rating	2 off voltage free change-over switch contacts, 250Vac, 5A, 500VA max resistive
Cable Entries	7 x 3/4" NPT (supplied with 4 stopper plugs)

Junction Box/Stowage Point

Enclosure Material	GRP with carbon loading
Terminals	2 x AWG #14 conductor capacity
Stowage Device	Insulated 0.79" diameter pin
Cable Entries	1 x M20
Clamp Cable Connection	Quick Connect

Grounding Clamp

Clamp Design	2 pole with tungsten carbide contacts
Body	Stainless steel

Spiral Cable

Cable	Blue Cen-Stat Hytrel sheath (Static dissipative, chemical & abrasion resistant)
Conductors	2 x AWG #18 copper
Length	32 ft extended, 3 ft unextended (other options available)

Ordering Code	Product Description
PLUSMUA1A3*	Earth-Rite PLUS™ Static Grounding System, Selectable 110/120Vac or 220/240Vac including Heavy Duty grounding clamp, 32 ft retractable spiral cable and GRP clamp stowage box
<i>Enquire for options list</i>	Explosion Proof Strobe Light (colour options amber, clear, blue, green and red) - Please enquire for more details
VESM02	M02 Retractable Cable reel with 50ft (15m) of 2 conductor Hytrel protected static grounding cable

* Additional Options Available

The Earth-Rite PLUS forms part of the Earth-Rite range of Static Grounding and Bonding Equipment available from Newson Gale



Leading the way in hazardous area static control

www.newson-gale.com

Newson Gale Inc
460 Faraday Avenue
Unit B, Suite 1
Jackson, NJ 08527
USA

Tel: +1 732 961 7610

Fax: +1 732 791 2182

Email: groundit@newson-gale.com

Newson Gale Ltd
Omega House
Private Road 8
Colwick, Nottingham
NG4 2JX, UK

Tel: +44 (0)115 940 7500

Fax: +44 (0)115 940 7501

Email: groundit@newson-gale.co.uk