

Earth-Rite® MGV

Static Grounding System

Drivers Operating Instructions

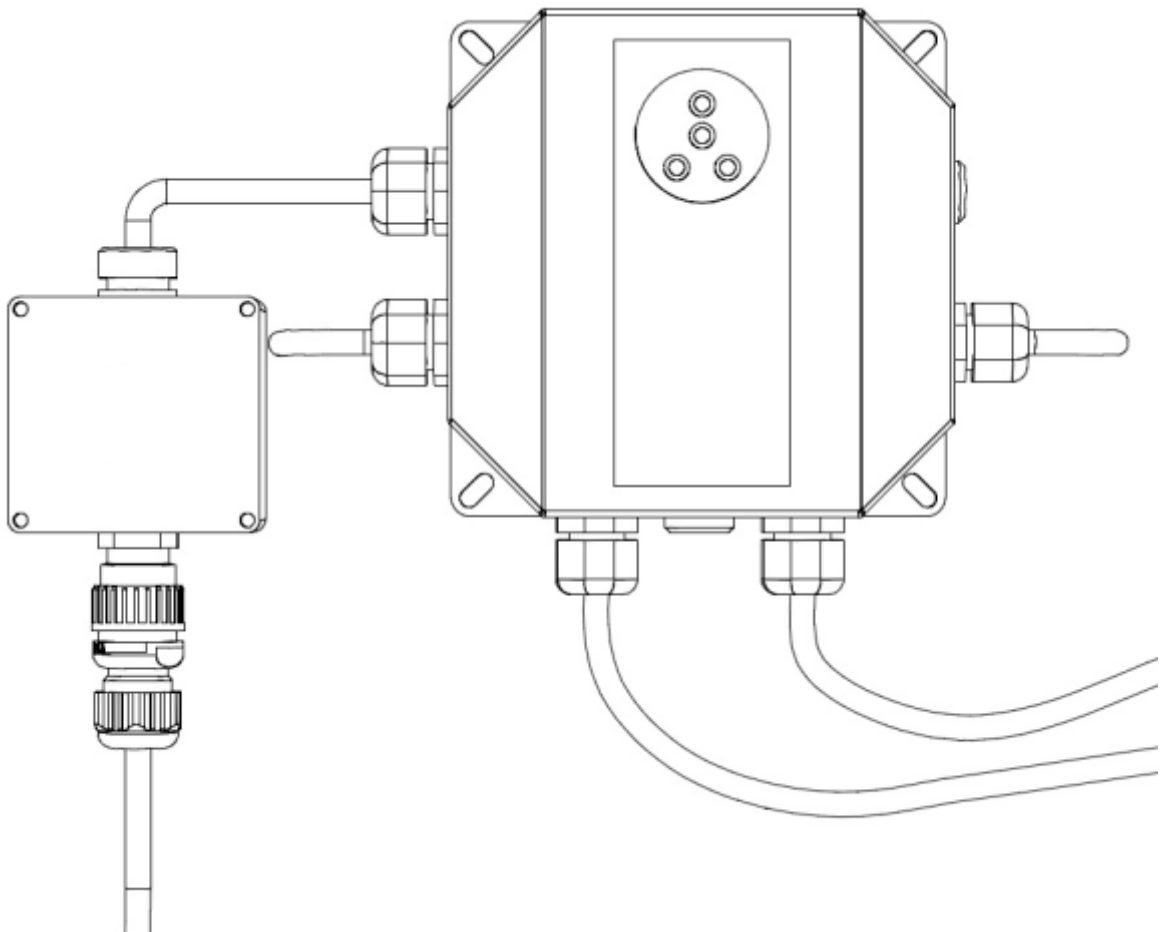

Leading the way in hazardous area static control

www.newson-gale.com

CONTENTS

Description of the Earth-Rite MGV	2
Earth-Rite MGV components	4
Suitable grounding points located on sites	5
Instructions for connecting the MGV system to site grounding points	6
Instructions for connecting the MGV system to portable grounding rods	9

Earth-Rite® MGV Static Grounding System

What is the Earth-Rite MGV?

The Earth Rite MGV is an electrostatic grounding system that protects drivers, operators, equipment and product from the ignition hazards associated with static electricity. Static electricity is a well known ignition hazard in industries where flammable and combustible materials are handled or processed. The MGV (**M**obile **G**round **V**erification) system ensures that the risk of a fire or explosion caused by static electricity is removed from the material transfer process.

Why is static electricity an ignition source?

When materials and liquids are in motion, static electricity is created as a natural by-product of the materials' contact with the components of the truck's collection and containment system. Static electricity can accumulate on components like the hose, hose couplings, tank container and the truck chassis. If the truck is not grounded (earthed) the static electricity will build up on these components and accumulate to levels that will result in an uncontrolled static discharge in the form of a hot spark. The energy levels of incendive static sparks from trucks exceed the minimum ignition energy (MIE) levels of the majority of combustible materials.

What does the MGV system do?

The MGV system is designed to ensure static electricity generated by the material transfer process cannot accumulate on the truck or any conductive parts attached to the truck (e.g. hose). It achieves this by ensuring the truck is connected to a good static dissipative ground. Grounding the vehicle means that the vehicle is attached to the general mass of earth, which can immediately absorb and redistribute static charges, forcing the charges to flow off the truck immediately. This ensures no sparks can be discharged due to the accumulation of static electricity.

How does the MGV work?

The MGV performs two tests critical to ensuring that the truck is connected to a good static dissipative ground connection for the *duration* of the material transfer process.

Test 1: Static Ground Verification

The MGV system ensures that the object to which it is connected has a low enough connection resistance with the general mass of the earth to dissipate static charges off the truck. This resistance level must be verified by the MGV system as being *below* a maximum resistance value.

Test 2: Continuous Ground Loop monitoring

When the MGV verifies that the object will act as a good static ground connection, it *continuously* monitors the grounding clamp's connection to the verified grounding point, ensuring that its connection resistance never rises above 10 ohms. This function also measures the integrity of the MGV's connection to the truck.

Any static charges that are generated by the transfer process will pass from the truck and hoses through the MGV's truck connections, through the system and down to earth through the grounding clamp.

Ground status indicators

When both tests are confirmed as being positive, 3 green LEDs pulse continuously on the system. This indicates that the truck is now connected to ground and is protected from static ignition hazards. If the MGV has not verified that the truck is connected to a static ground, or the ground loop resistance is higher than 10 ohms, the single red LED will remain lit.

Interlock options

The MGV may be interlocked with the transfer system such that if a static ground connection is not established, or is lost during transfer, it halts the movement of material. This stops the generation of electrostatic charges while the truck is without the safety of a verified static ground connection.

If an interlock with the transfer system is not required the MGV can be interlocked with additional equipment such as strobe lights or sounders.

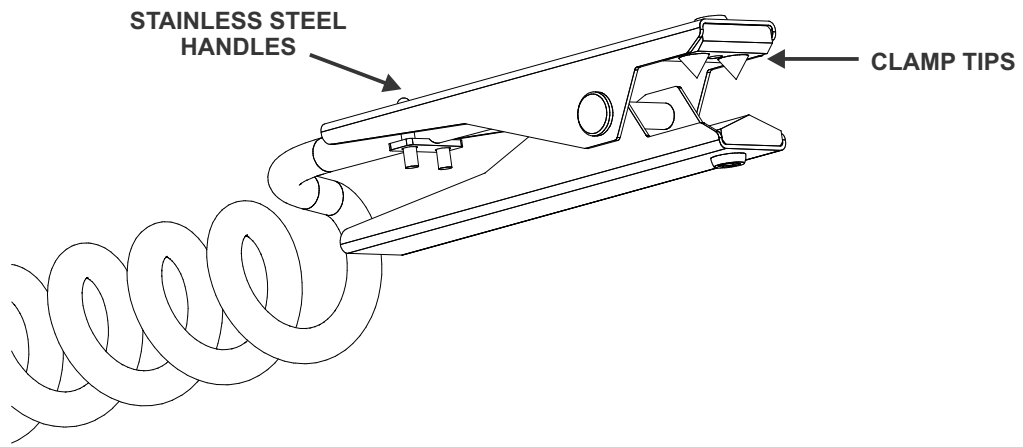
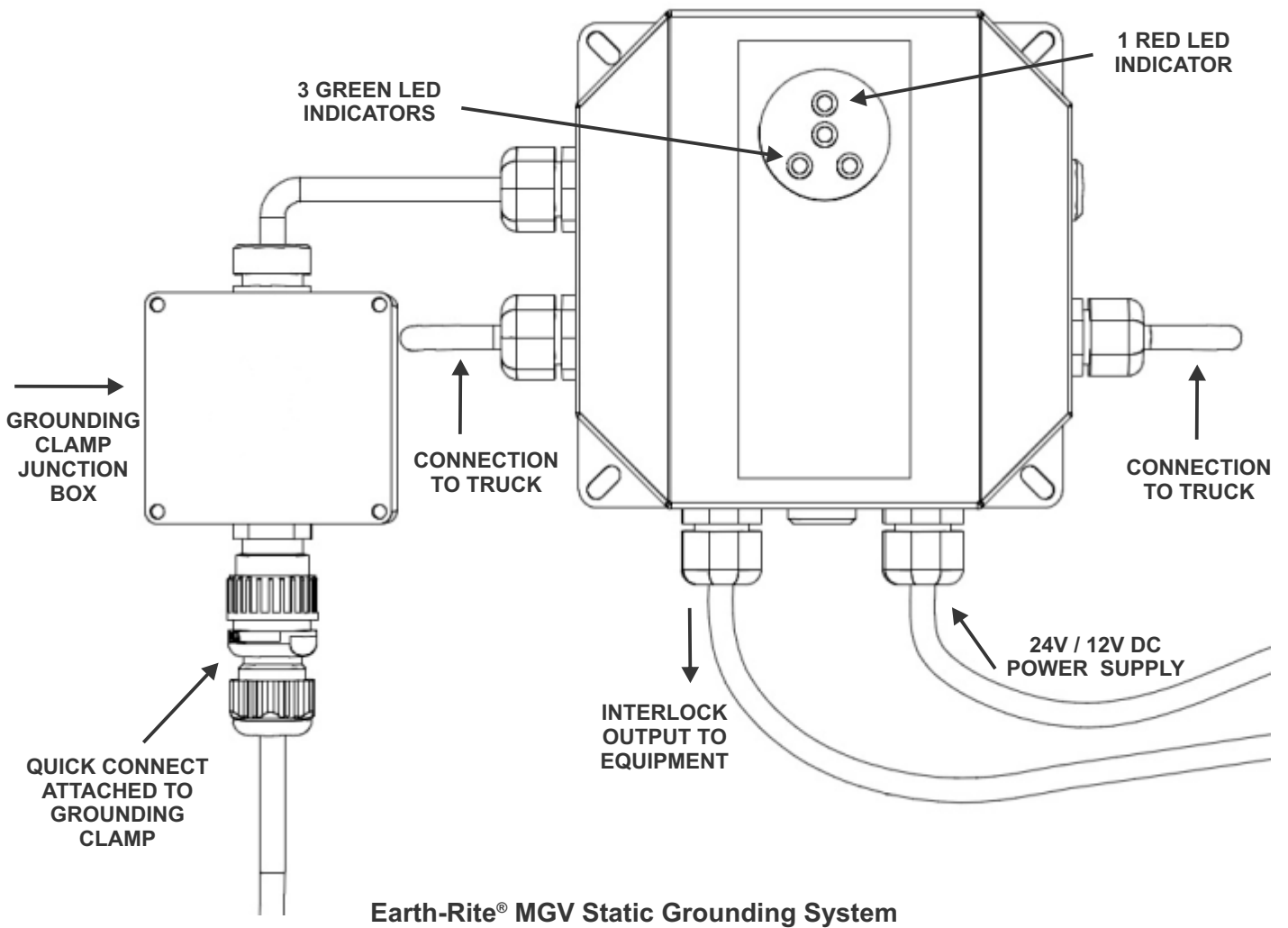

Grounding points located on sites.

Request information from the site supervisor regarding the possible location of designated grounding points. These will be metal objects likely to be grounded through their inherent and permanent contact with the ground.

Examples of grounding points include, but are not limited to:

- Installed grounding bus-bar systems and ground rods connected to bus-bars
- Building structures like storage tanks and lightning conductors on the side of buildings.
- Pipes running into the ground.
- Plant equipment, with electrical fault protection like pump motors.

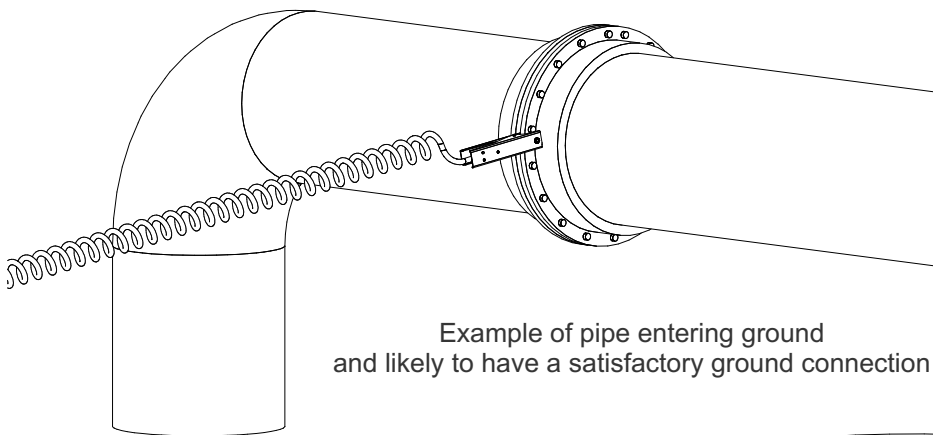

Example of pipe entering ground and likely to have a satisfactory ground connection

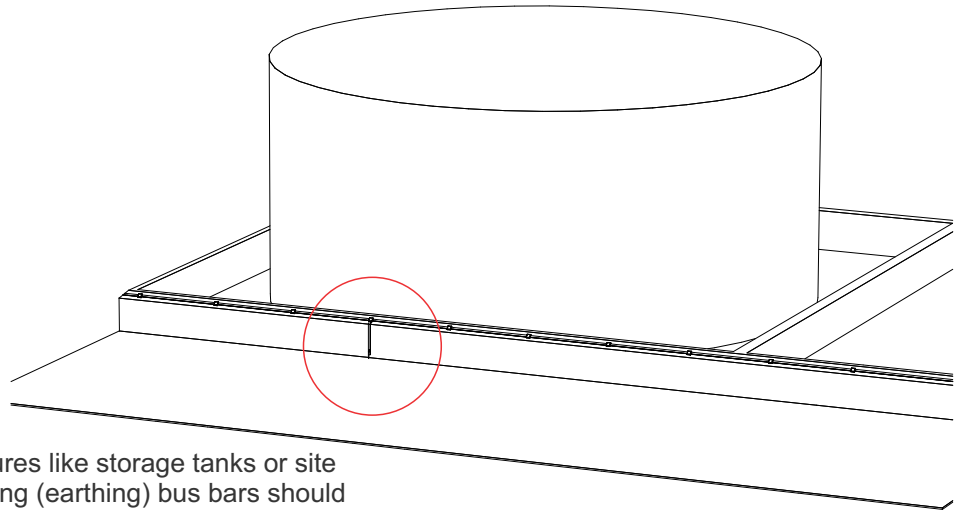

Structures like storage tanks or site grounding (earthing) bus bars should have low resistance connections to earth.

ATTENTION:

DO NOT CONNECT THE MGVS TO STRUCTURES THAT DO NOT HAVE A CONNECTION RUNNING INTO THE GROUND. THIS INCLUDES STRUCTURES THAT MAY SIT ON TOP OF THE GROUND, BUT DO NOT RUN INTO THE GROUND. EXAMPLES INCLUDE, TEMPORARY FENCING, STAIRS ON THE SIDE OF BUILDINGS, TEMPORARY SIGNS, SCAFFOLDING.

Earth-Rite MGV Operating Manual Instructions

Note: the first operation in the material transfer process should be the grounding of the truck. This is Standard Operating Procedure in locations where trucks are being filled or emptied with combustible materials or within combustible atmospheres.

When the truck is parked in the best location to ground the truck and collect or deliver the material, the first operation that must be completed is satisfactory grounding of the truck.

1. Insert the grounding clamp into the junction box of the MGV system.

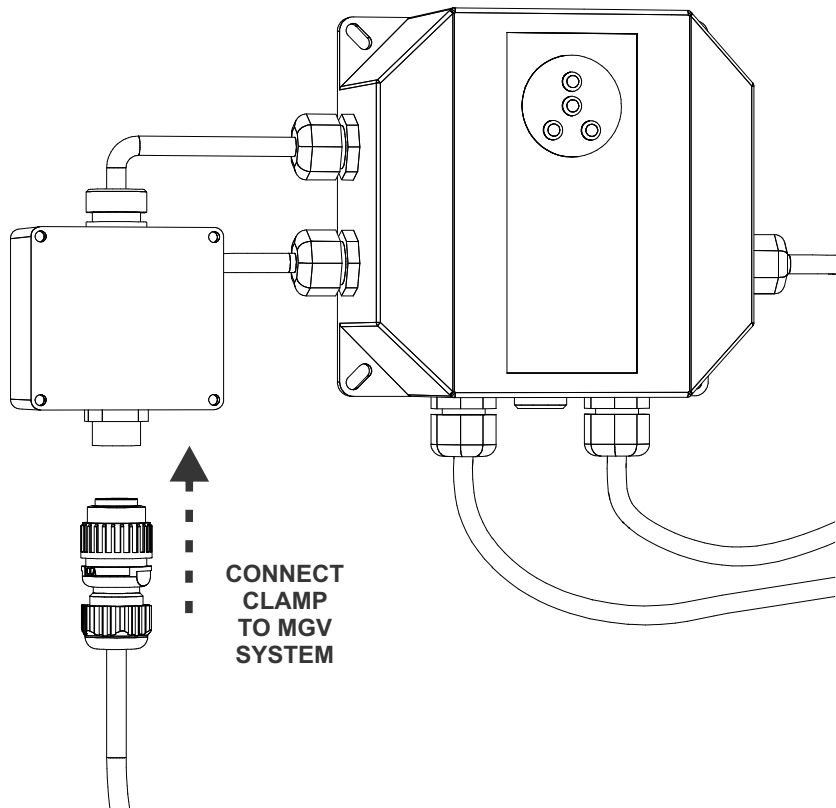

2. Look for a metal object entering the ground. Examples of grounded structures are:

- Pipes running underground.
- Building structures like tanks.
- Installed ground rods connected to site ground bus-bars.
- Plant equipment like pump motors.

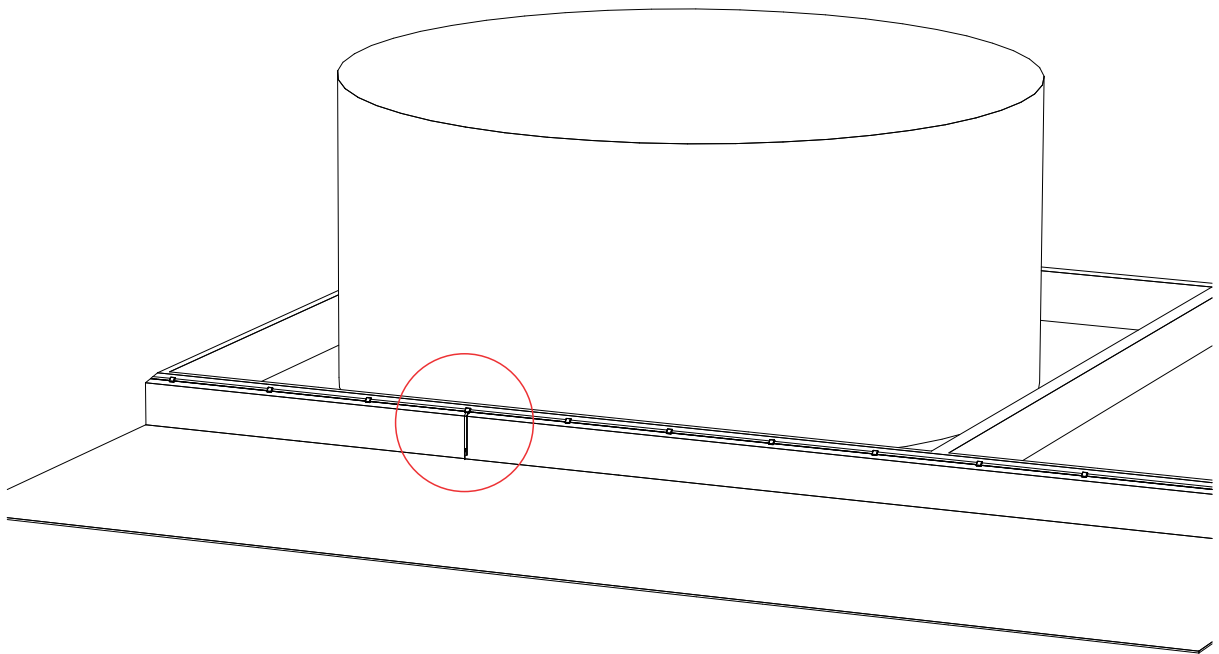

Sites may have identified grounding points, such as ground rods connecting site grounding bus bars to earth. Request information from the site supervisor about potential grounding points.

3. Connect the clamp to the grounding point.

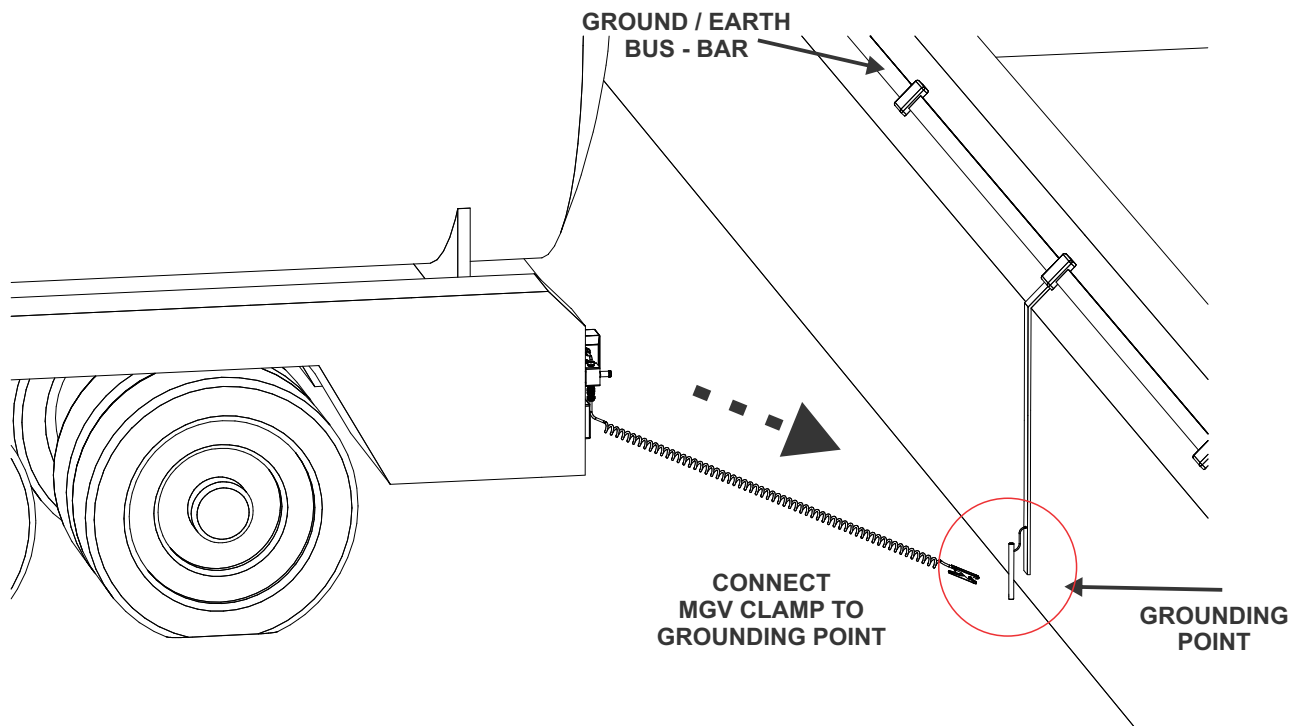

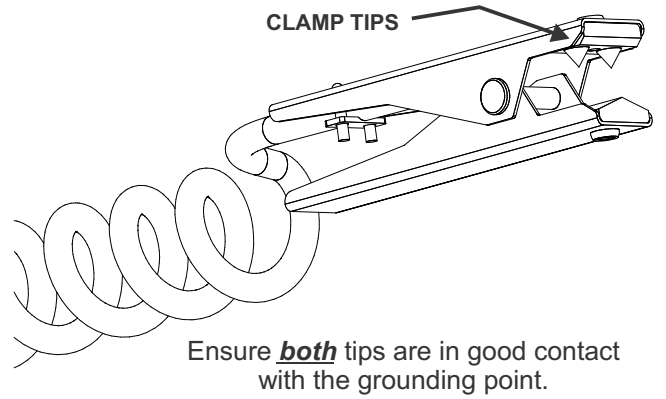
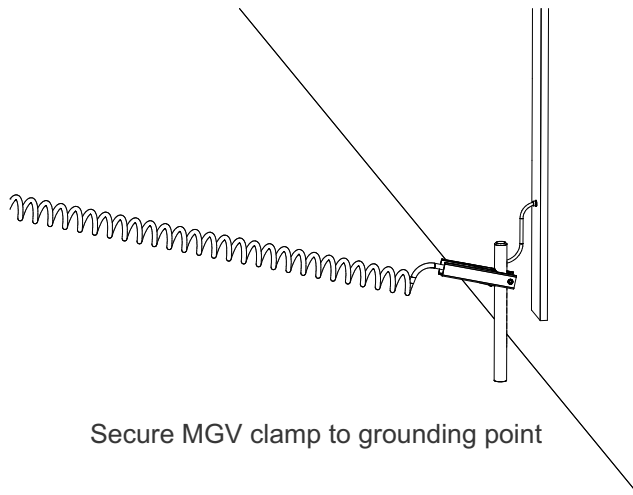

4. **Observe the MGV system LEDs.**
5. **If green LEDs are pulsing, the truck is securely grounded. Proceed with the transfer operation.**

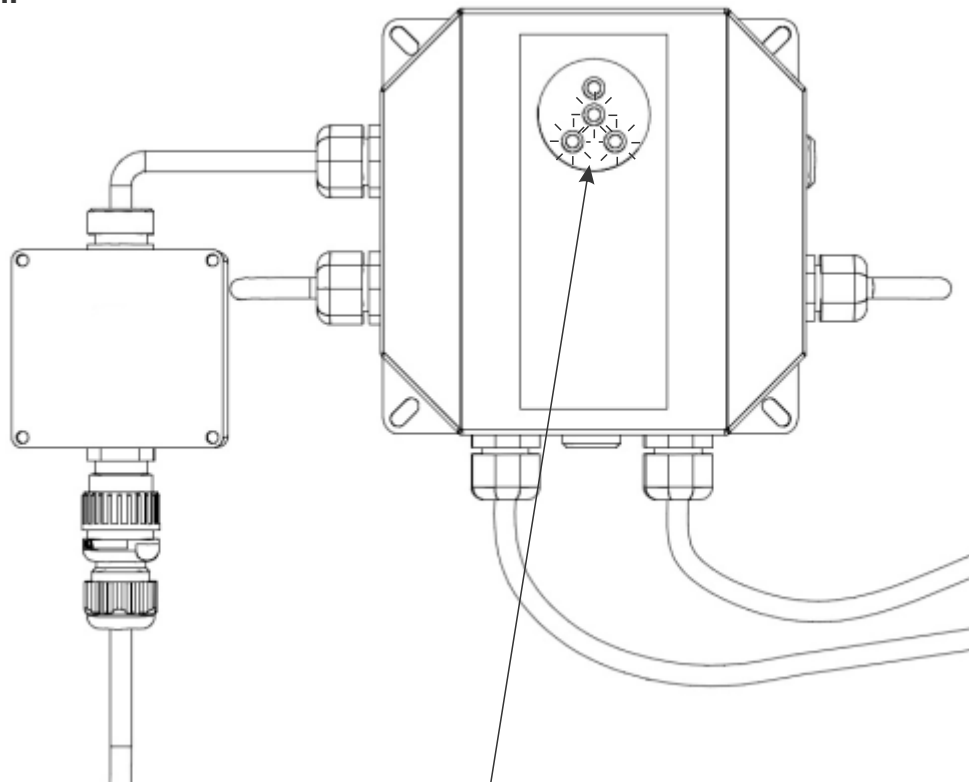

Observe indicators. When truck is grounded 3 green LEDs will pulse continuously.

6. **If the red LED is lit, adjust the clamp back and forth to enable the clamp tips to penetrate through contact inhibitors such as rust, coatings, product deposits and dirt.**
7. **If a positive indication cannot be established, the point is not connected to ground and a separate grounding point must be located.**

If structures with ground connections are not available and portable ground rods are required:

1. Take the 4 rods and secure the 3 ground wires to each of the 4 rods.
2. Insert all ground rods to the depth specified by the markings etched into the rod.

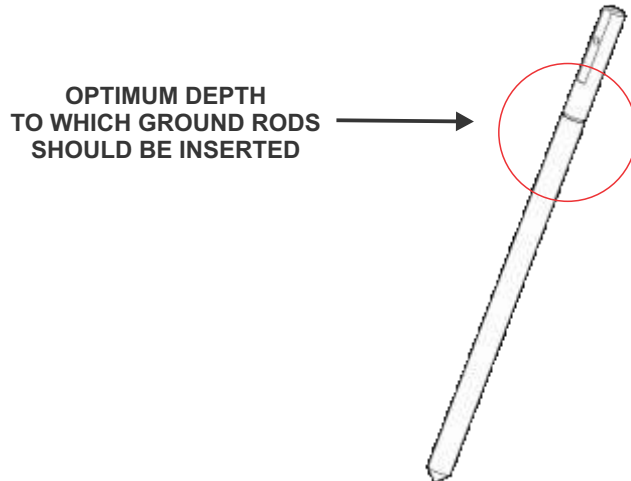

3. Ensure the rods are equally spaced to the maximum length permitted by the ground wire.

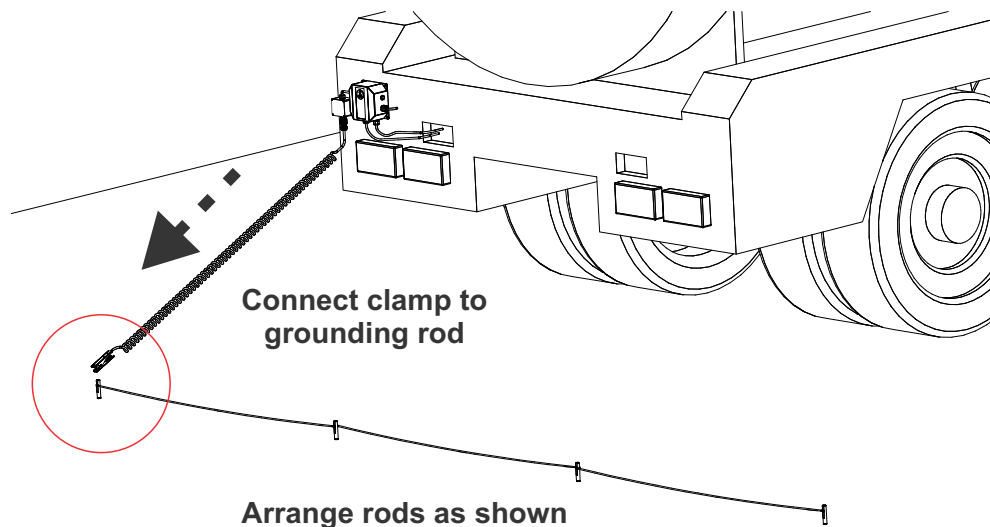

4. Connect the MGV system to one of the rods and observe the LED indicators.
5. If the MGV does not register a positive grounding of the truck, locate the rods in a different area and repeat steps 1 to 4 until a registered ground connection is established.

Note: in the event that a verified ground connection cannot be established contact your supervisor to determine the most appropriate course of action.



**Newson
Gale®**

Leading the way in hazardous area static control

www.newson-gale.com



Newson Gale Inc

460 Faraday Avenue
Unit B, Suite 1
Jackson, NJ 08527
USA

Tel: +1 732 961 7610

Fax: +1 732 791 2182

Email: groundit@newson-gale.com



Newson Gale GmbH

Ruhrallee 185
45136 Essen
Deutschland

Tel: +49 (0)201 89 45 245

Fax: +49 (0)201 42 60 026

Email: erdung@newson-gale.de



Newson Gale Ltd

Omega House
Private Road 8
Colwick, Nottingham
NG4 2JX, UK

Tel: +44 (0)115 940 7500

Fax: +44 (0)115 940 7501

Email: groundit@newson-gale.co.uk